

ARTANY®

Arte em Home Office

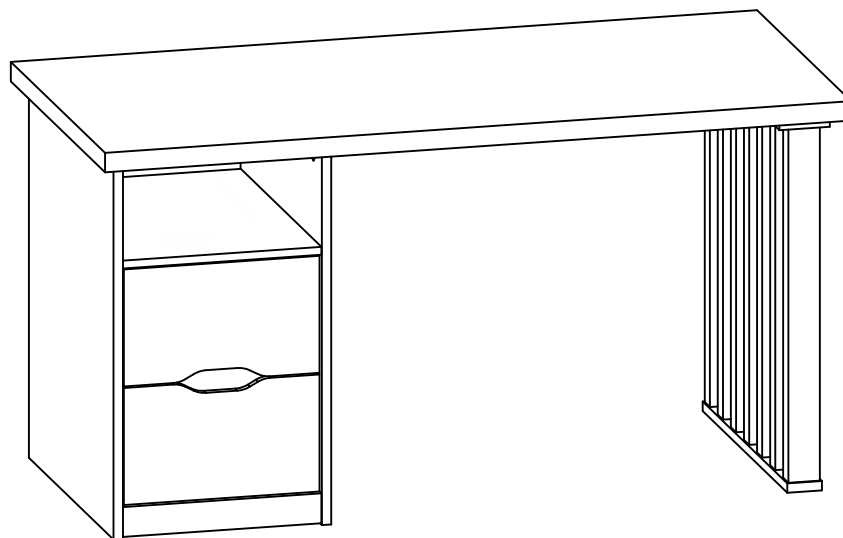
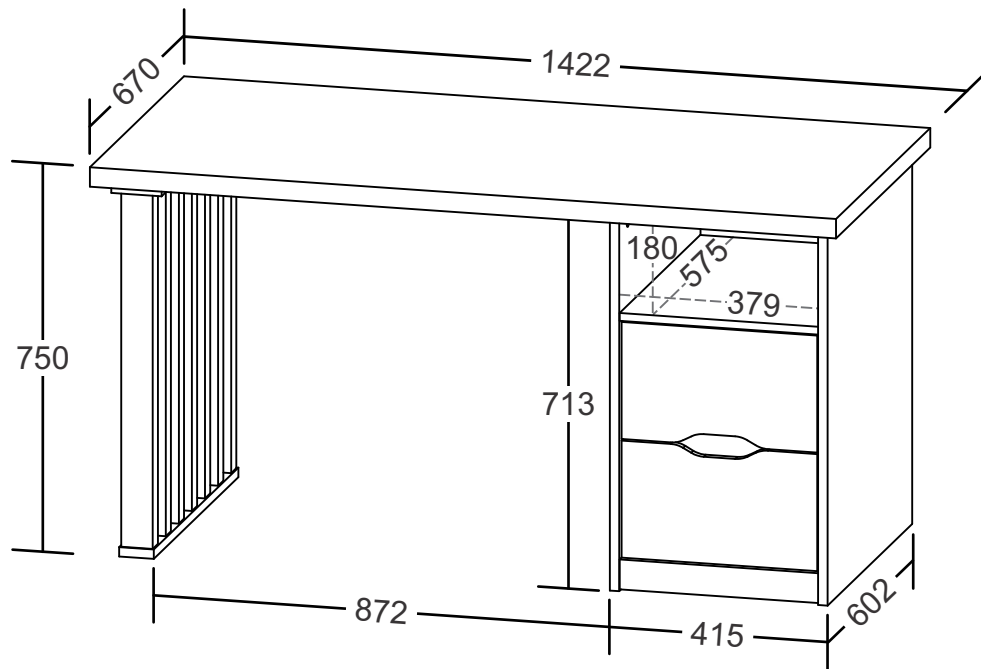

Florence

- Siga atentamente todas as instruções de montagem;
- Monte seu produto no local ou próximo de onde será colocado. Movimentações do produto já montado, podem avariá-lo;
- Faça a montagem em uma superfície limpa e plana. Aconselhamos usar a própria embalagem de papelão para forrar o chão;
- Verifique se as quantidades de peças e acessórios estão de acordo com o manual de montagem;
- Compare atentamente os furos de cada peça com a ilustração do manual;
- Utilize as ferramentas indicadas. Só utilize parafusadeira se tiver conhecimento e habilidade. O uso inapropriado pode danificar peças e/ou acessórios;
- Se o produto necessitar fixação na parede, tenha cuidado para não atingir fios e canos ao furar a parede.

Obs: Caso necessite solicitar peças de reposição, por favor, utilize os códigos dos mesmos.

- Siga con atención todas las instrucciones de armado.
- Arme su mueble en un lugar cerca donde será instalado. Mover el producto ya montado puede perjudicarlo.
- Haga el montaje en una superficie limpia y plana. Aconsejamos usar el propio embalaje de cartón para forrar el suelo.
- Asegúrese de que las cantidades de piezas y accesorios coincidan con el manual de montaje.
- Compare cuidadosamente los agujeros de cada pieza con la ilustración del manual.
- Utilice las herramientas indicadas. Sólo utilice atornillador automático si tiene conocimiento y habilidad. El uso inapropiado puede dañar piezas y/o accesorios.
- Si el producto necesita fijación en la pared, tenga cuidado de no alcanzar cables y tuberías al perforar la pared.

OBS: Si necesita solicitar piezas y / o accesorios de repuesto, por favor, utilice los códigos de los mismos.

- Follow carefully the assembly instructions.
- Assemble your furniture in a place near where it will be installed. Moving the assembled product can harm it.
- Make the assembly on a clean and flat surface. We recommend using the cardboard box to cover the floor.
- Make sure the quantities of parts and accessories match the assembly manual.
- Carefully compare the holes in each piece with the illustration in the manual.
- Use the indicated tools. Only use an automatic screwdriver if you have knowledge and skill. Improper use can damage parts and/or accessories.
- If the product needs fixing on the wall, be careful and don't reach cables and pipes when drilling the wall.

NOTE: If you need to request spare parts and/or accessories, please use the codes according of this instruction manual.

CONSERVAÇÃO E LIMPEZA

MANTENIMIENTO Y LIMPIEZA / MAINTENANCE AND CLEANING

Não expor o produto ao sol, altas temperaturas e umidade, mantendo-o em local seco e arejado. Para a limpeza, utilizar um pano seco e macio. Não é necessário o uso de materiais abrasivos ou álcool.

No exponga el producto al sol, altas temperaturas y la humedad. Mantener en local seco y ventilado. Para limpiar, utilice un paño suave y seco. No es necesario el uso de materiales abrasivos o alcohol.

Do not expose the product to sunlight, high temperatures and humidity. Keep it in a dry and ventilated place. To clean it, use a soft and dry cloth. It is not necessary to use abrasive materials or alcohol.

Garantia

Este certificado de Garantia é uma vantagem adicional oferecida ao consumidor, porém para que o mesmo tenha validade é imprescindível que seja apresentada a NOTA FISCAL de compra do produto e o número do lote (ver etiqueta).

Com este produto, a **Artany** tem como objetivo atender plenamente o proprietário-consumidor, proporcionando a garantia na forma aqui estabelecida, pelo período de 2 anos a partir da data da nota fiscal de compra. A **Artany** restringe a sua responsabilidade à substituição gratuita das peças defeituosas, em caso de defeitos ou avarias devidamente constatados como sendo de fabricação, durante a vigência desta garantia.



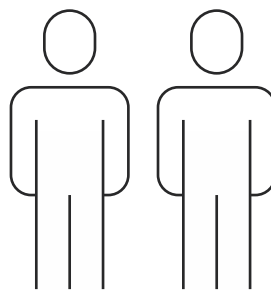
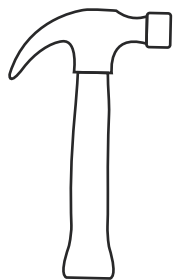

A **Artany** declara a garantia nula e sem efeito se o produto for alterado, adulterado, molhado ou consertado e ainda pela prática de montagem inadequada. Também será considerada nula em casos de força maior, como aqueles causados por agentes da Natureza (chuvas, incêndios, excesso de umidade...).

Para exercer seus direitos de comprador é importante que antes de montar seu produto você leia com atenção as instruções de cada passo do manual de montagem que acompanha o móvel.

Caso o produto não esteja em conformidade, entre em contato com a loja onde efetuou a compra ou com o nosso Serviço de Atendimento ao Cliente através do fone (41) 3556 1500 ou do e-mail assistencia@artany.com.br, e faça sua reclamação, apontando os defeitos técnicos observados, que teremos o maior prazer em atendê-lo. Para agilizar o seu atendimento, tenha sempre em mãos o manual de montagem com os respectivos números das peças defeituosas conforme descritas no manual.

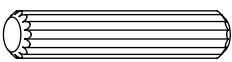
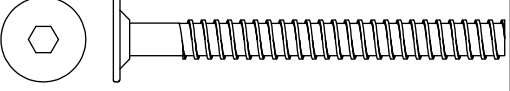
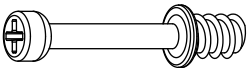
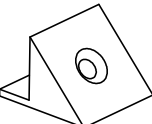
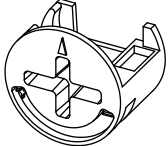
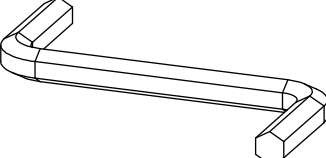
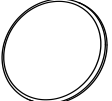

Lista de materiais | Lista de materiais | Hardware list

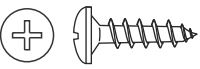
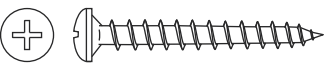
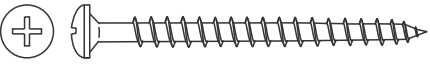
A		Cavilha Tarugo Dowel Ø6x30mm	56	I		Parafuso / Tornillo / Screw Ø7,0x60mm Sextavado	08
B		Minifix Minifix Minifix Ø7x32mm	16	J		Suporte triangular Soporte triangular Triangle support	02
C		Tambor Tambor Minifix Cam Ø15x12mm	16	K		Chave Zeta / Clave Zeta / Allen Key	01
D		Tapa furo adesivo Adhesivo Hole Cover Ø18mm	08	L		Sapata / Pata / Foot 12x48mm	06
E		Parafuso Tornillo Screw Ø3,5x12mm CC	24	M		Corrediça telescópica Corrediza telescópica Telescopic slide 400mm	04
F		Parafuso Tornillo Screw Ø4,0x14mm CP	02				
G		Parafuso / Tornillo / Screw Ø4,0x30mm CP	04				
H		Parafuso / Tornillo / Screw Ø4,0x45mm CP	06				

.1

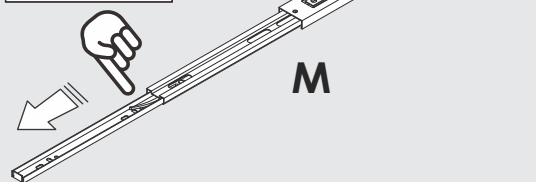
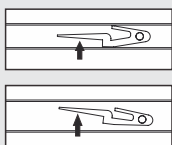

.2

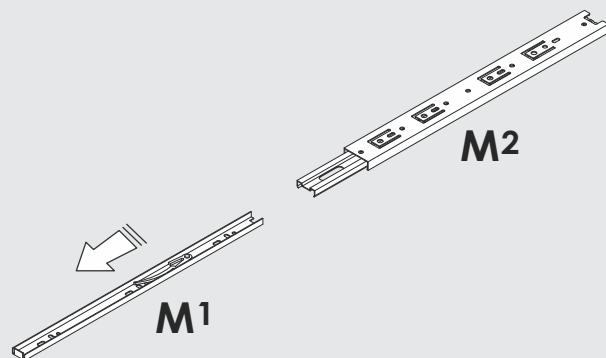

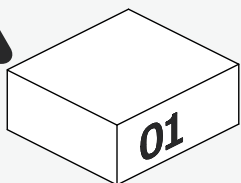

O número na borda da peça corresponde ao manual.

Para remover, use um pano com álcool em gel ou álcool 70%.

El número que aparece en el borde de la pieza corresponde al manual.

Para retirarlo, utilice un paño con alcohol en gel o alcohol al 70%.

The number on the edge of the piece corresponds to the assembly guide.

To remove it, use a cloth with alcohol gel or 70% alcohol.

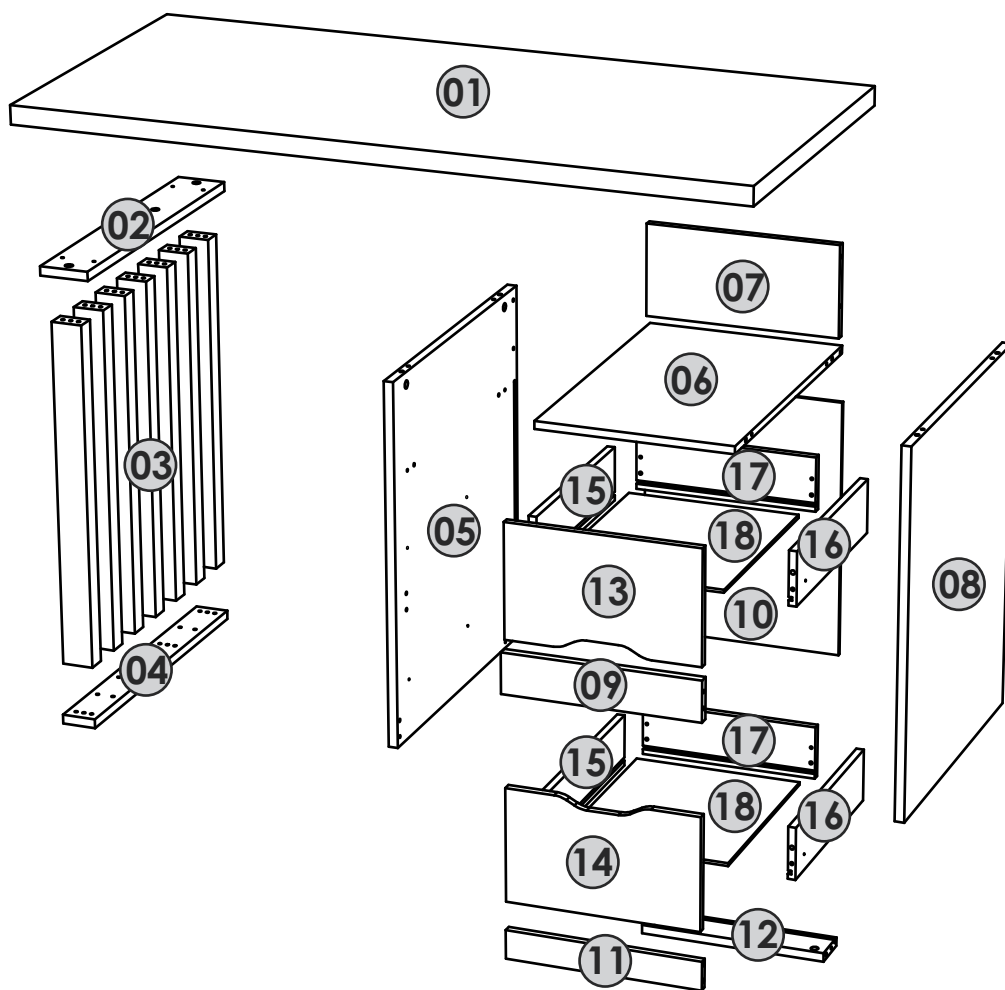

Item	Descrição Descripción Description			Dimensões Dimensiones Dimensions mm			Qty Ctd Qty
	Português	Español	English	Comp. Largo Length	Larg. Ancho Width	Esp. Grosor Thickness	
01	Tampo	Tapa	Top	1422	670	37	1
02	Tampo pé	Tapa pie	Foot top	602	96	18	1
03	Pé	Pie	Foot	674	60	37	7
04	Base pé	Base pie	Base foot	602	66	18	1
05	Lateral esquerda	Lado izquierdo	Left side	710	602	18	1
06	Prateleira	Anaquele	Shelf	379	596	15	1
07	Traseira superior	Trasera superior	Top back	379	181	15	1
08	Lateral direita	Lado derecho	Right side	710	602	18	1
09	Travessa	Travesaño	Crosspiece	379	80	18	1
10	Traseira	Trasero	Back	504	390	6	1
11	Rodapé frontal	Rodapié frontal	Front baseboard	379	57	15	1
12	Rodapé traseiro	Rodapié trasero	Back baseboard	379	80	18	1
13	Frente gaveta superior	Frente cajón superior	Top drawer front	373	223	15/18	1
14	Frente gaveta inferior	Frente cajón inferior	Bottom drawer front	373	223	15/18	1
15	Lateral esquerda gaveta	Lado izquierdo cajón	Drawer left side	400	105	15	2
16	Lateral direita gaveta	Lado derecho cajón	Drawer right side	400	105	15	2
17	Traseira gaveta	Trasero del cajón	Drawer back	354	107	15	2
18	Fundo gaveta	Fundo del cajón	Drawer bottom	411	334	6	2

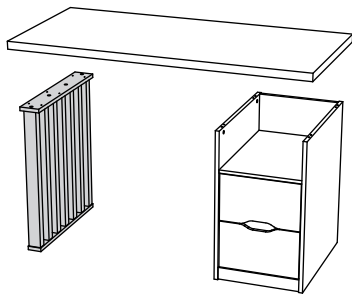

01

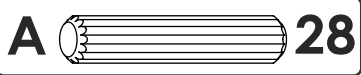
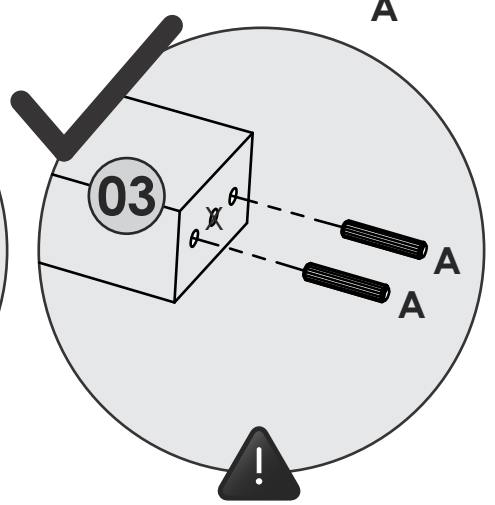
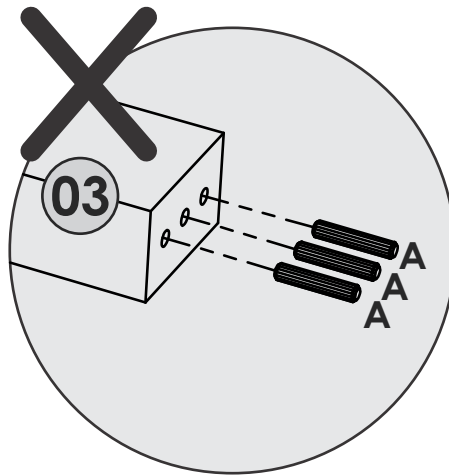
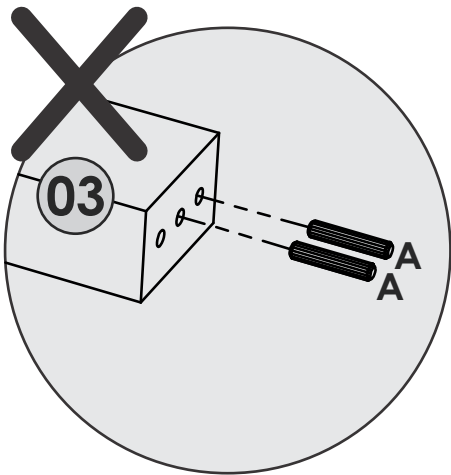
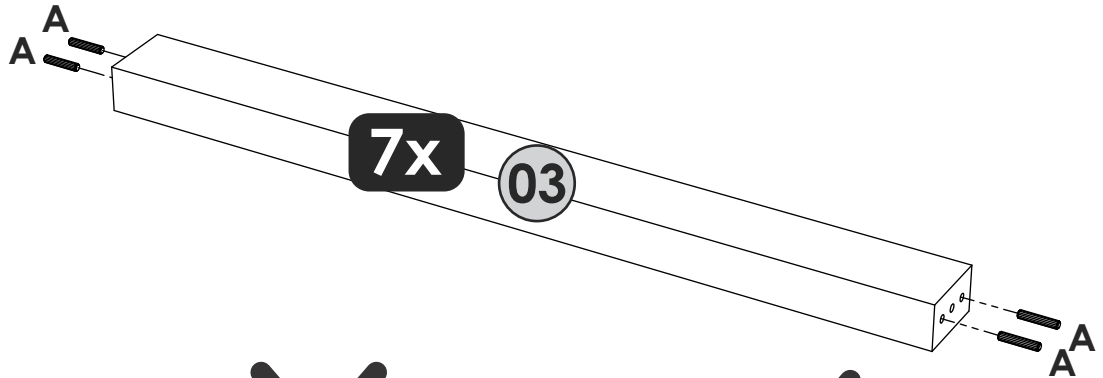

02

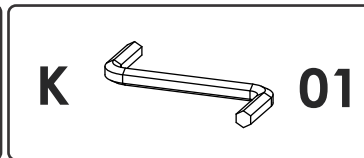
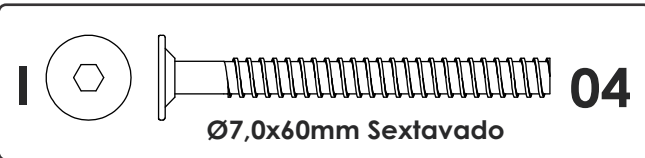
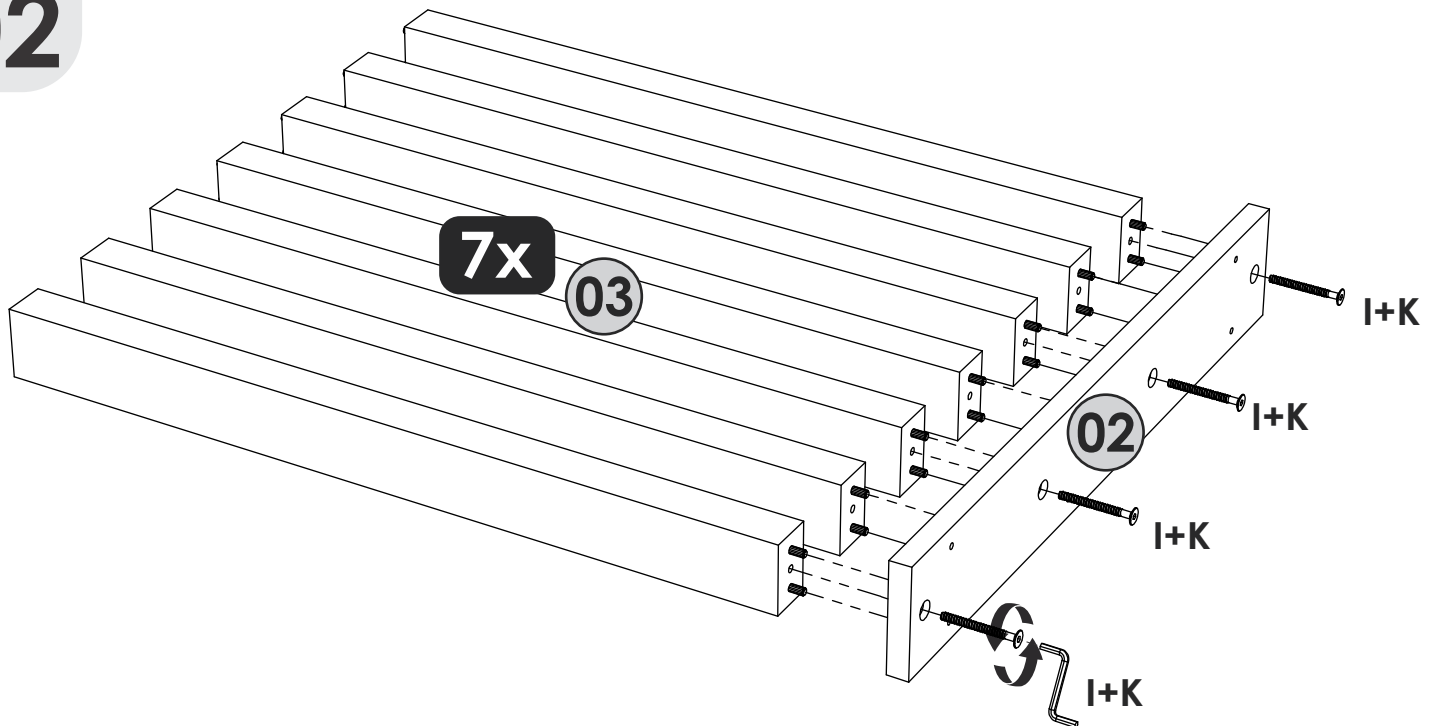

03

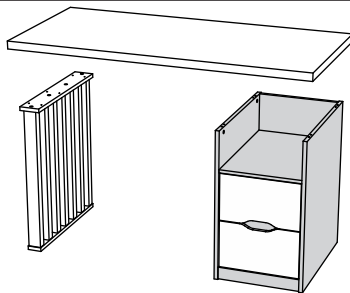
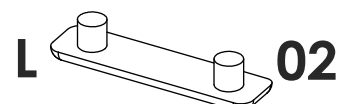
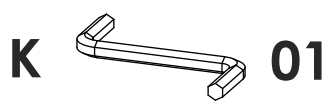
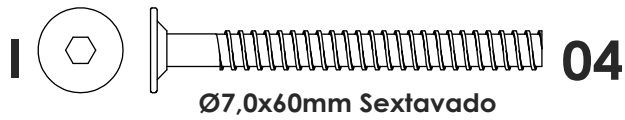
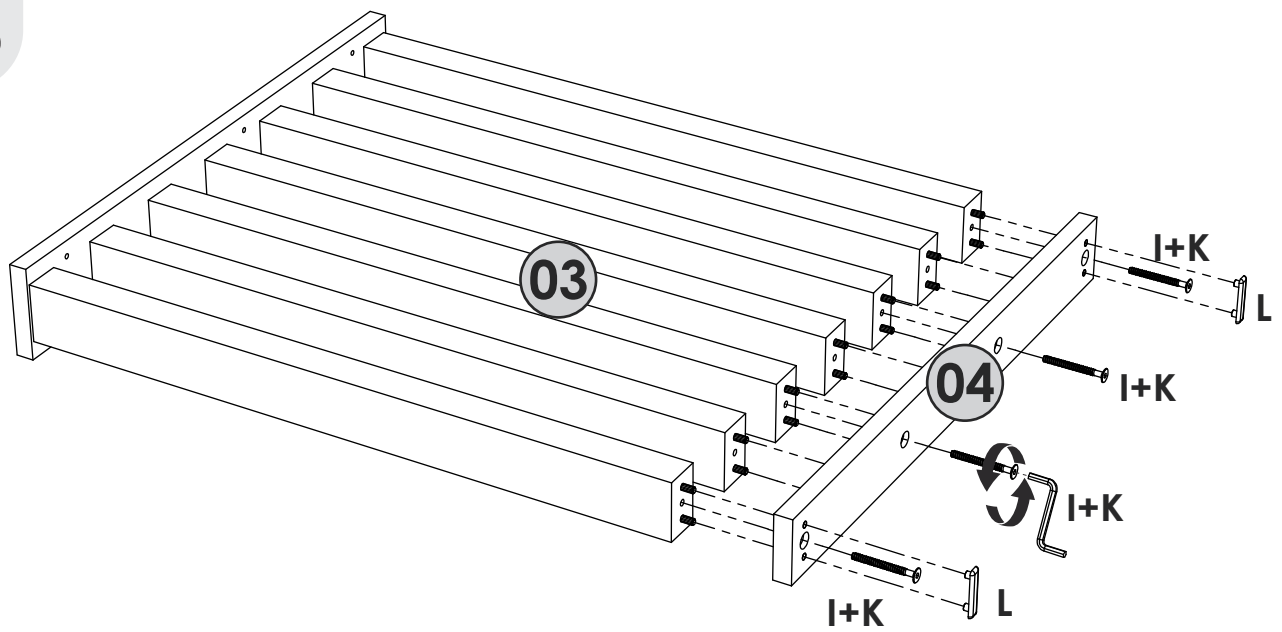

04

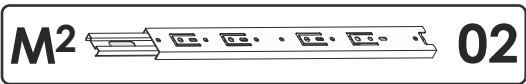
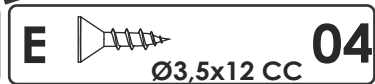
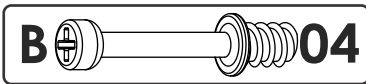
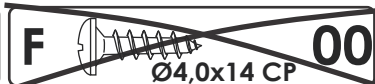
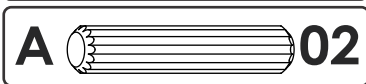
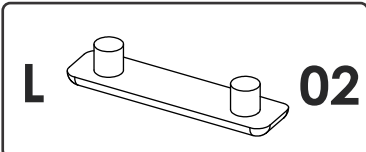
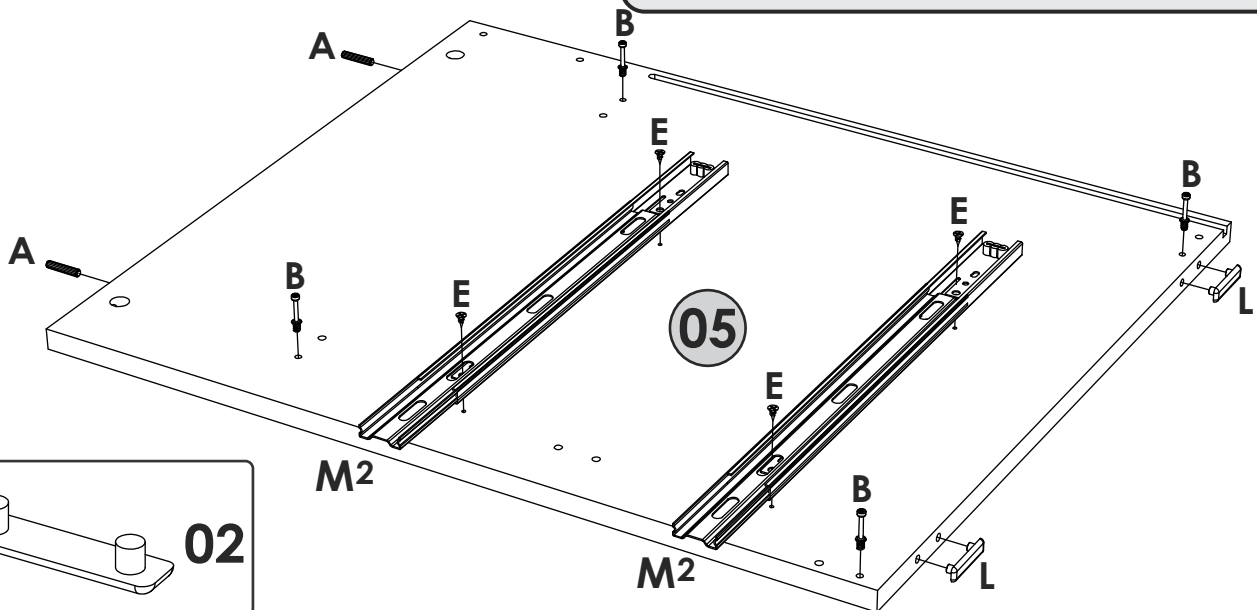
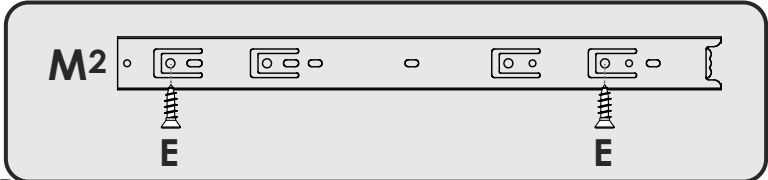

05

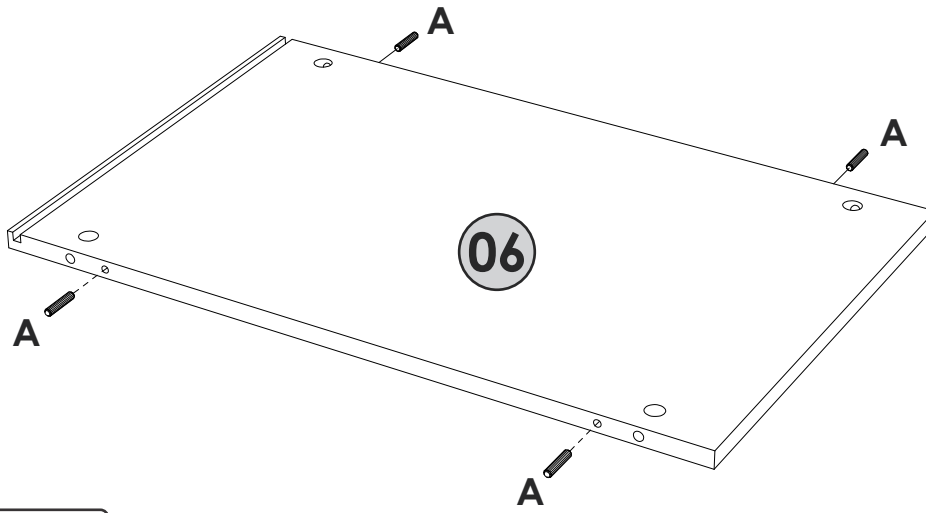

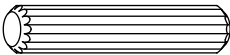
A  **04**

06

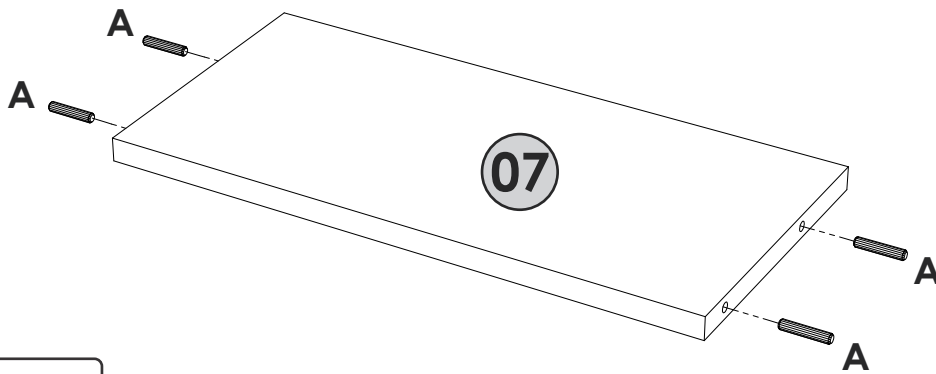

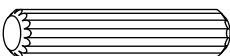
A  **04**

07

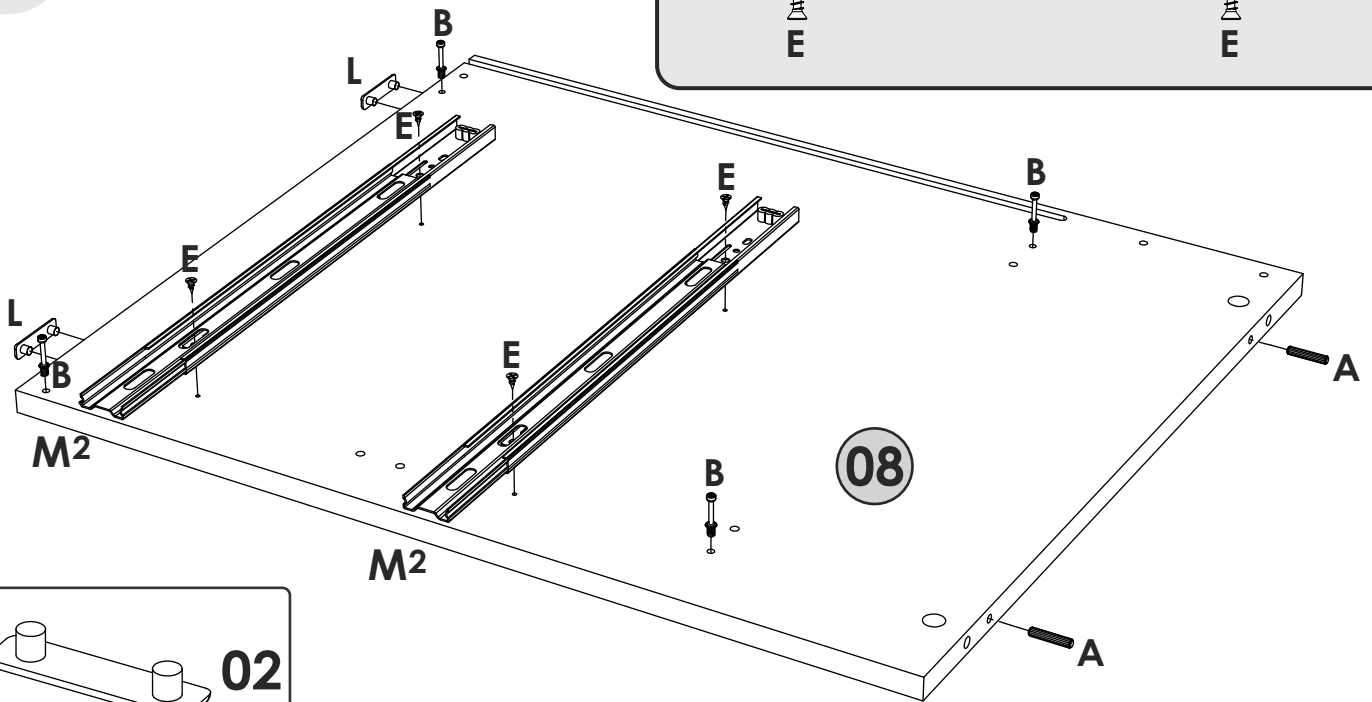
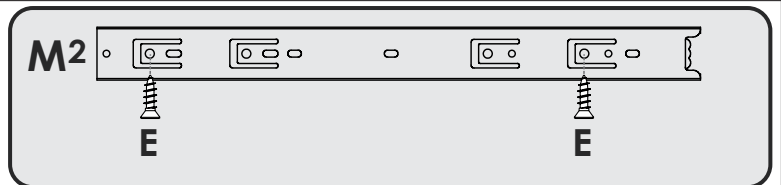

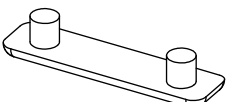
L  **02**

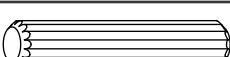
A  **02**

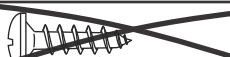
~~**F**  **00**
Ø4,0x14 CP~~

B  **04**

E  **04**
Ø3,5x12 CC

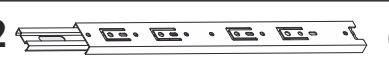
M2  **02**

08

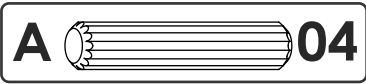
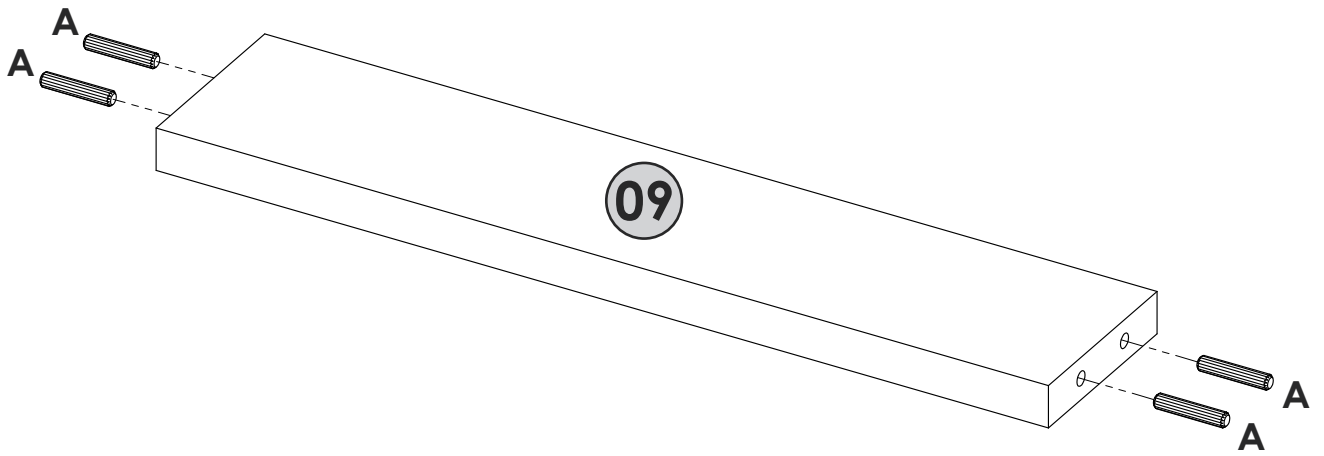

09

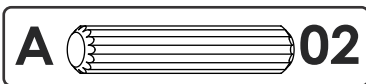
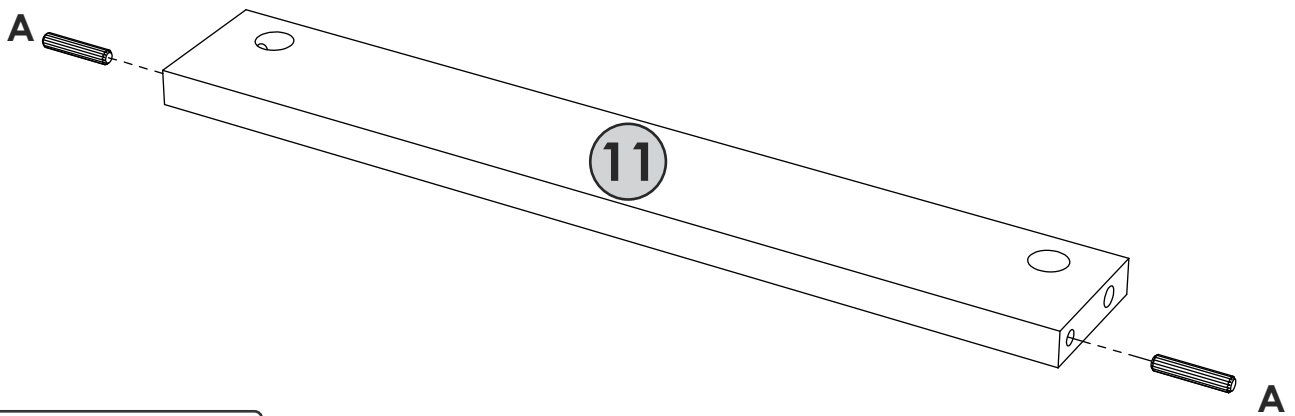

10

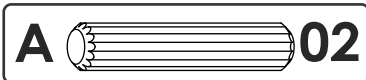
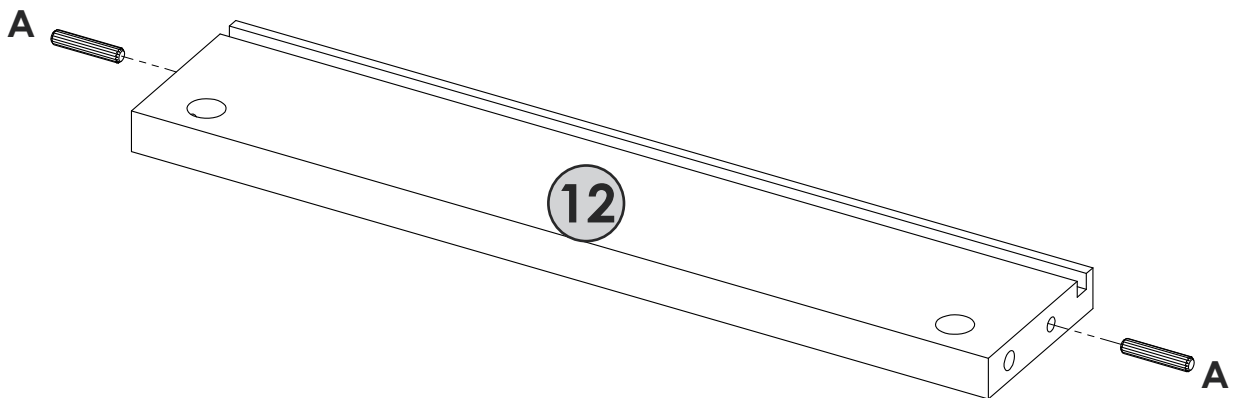

11

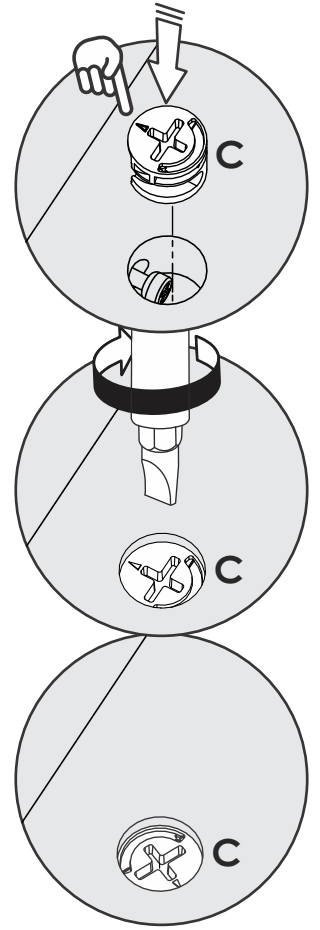
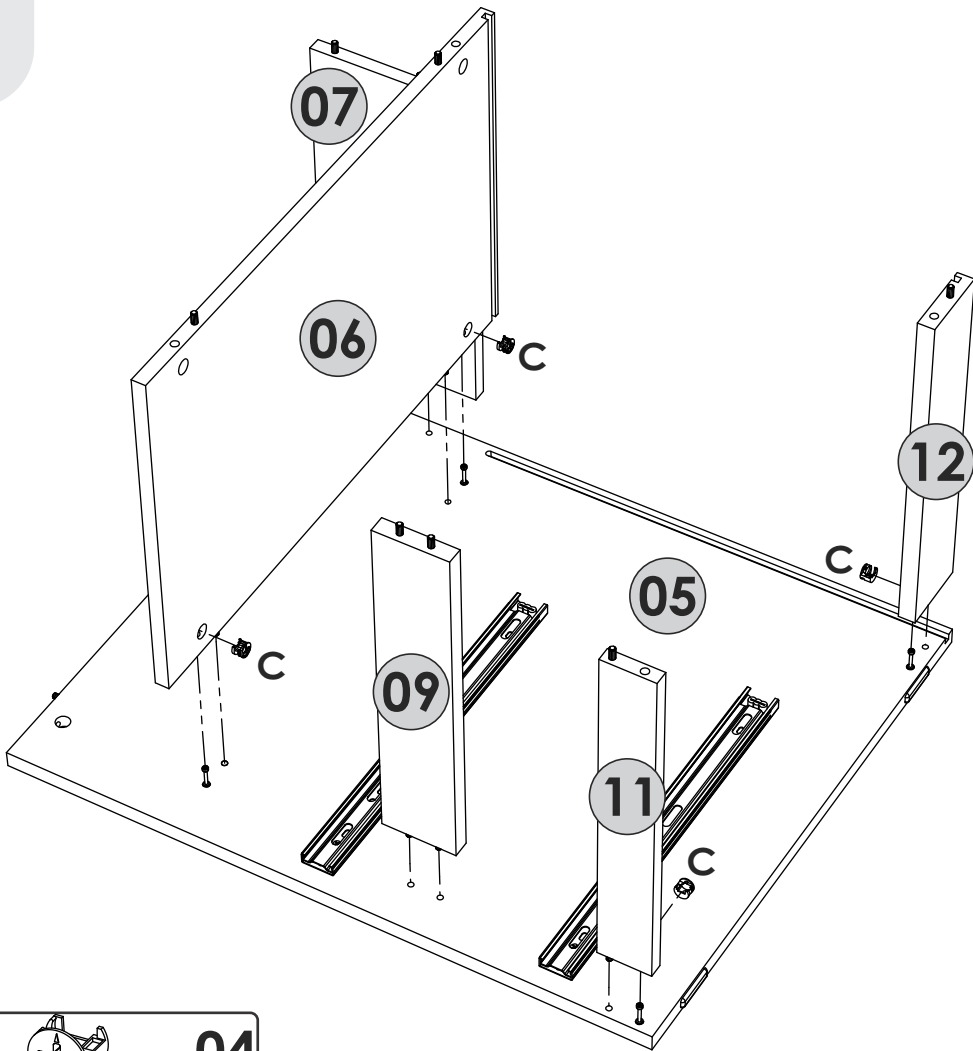

12

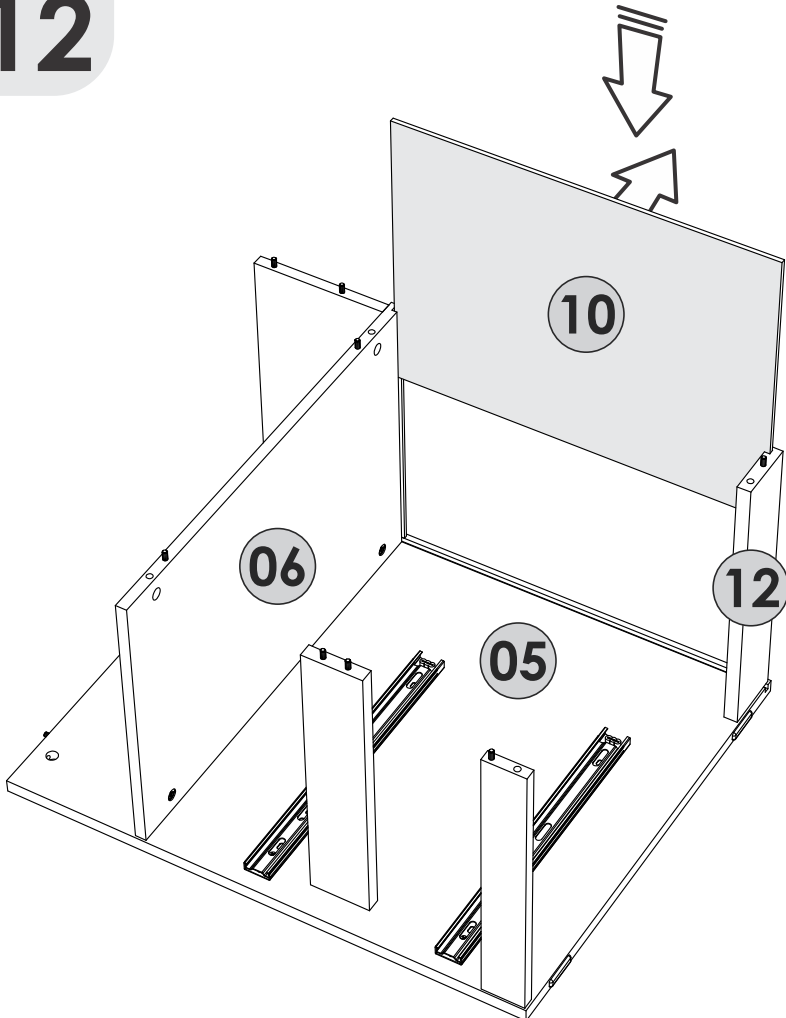

Lado do acabamento virado para fora
Lado recubierto para fuera
Revested side turned outside

13

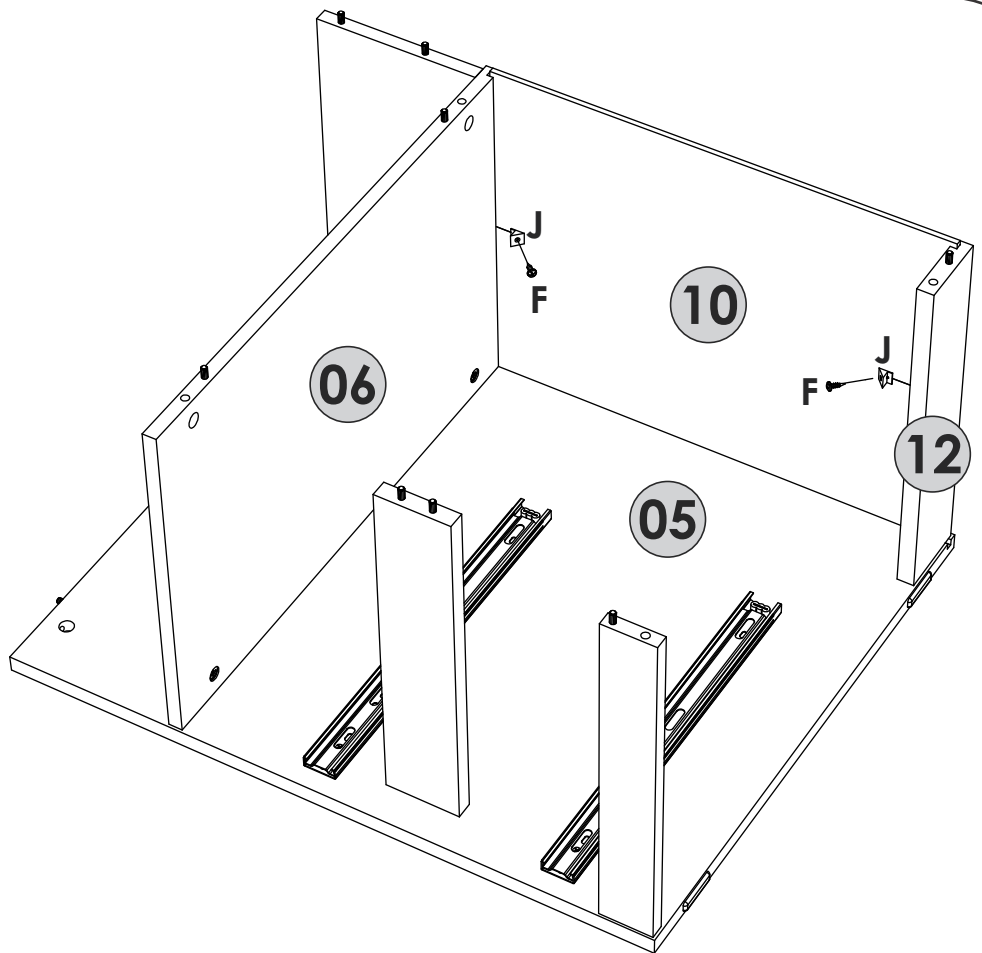
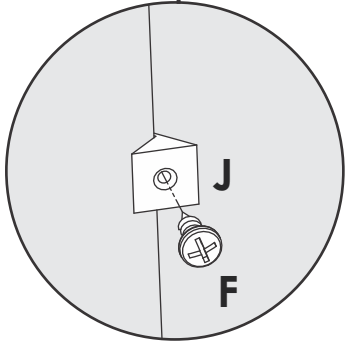
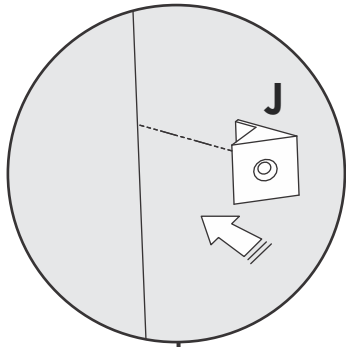

02



02

Ø4,0x14 CP

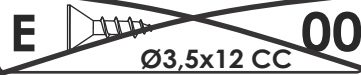

00

Ø3,5x12 CC



00

Ø3,5x30 CP

14

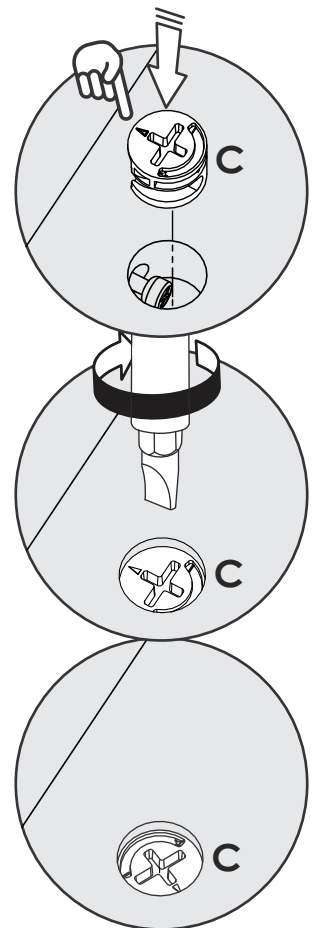
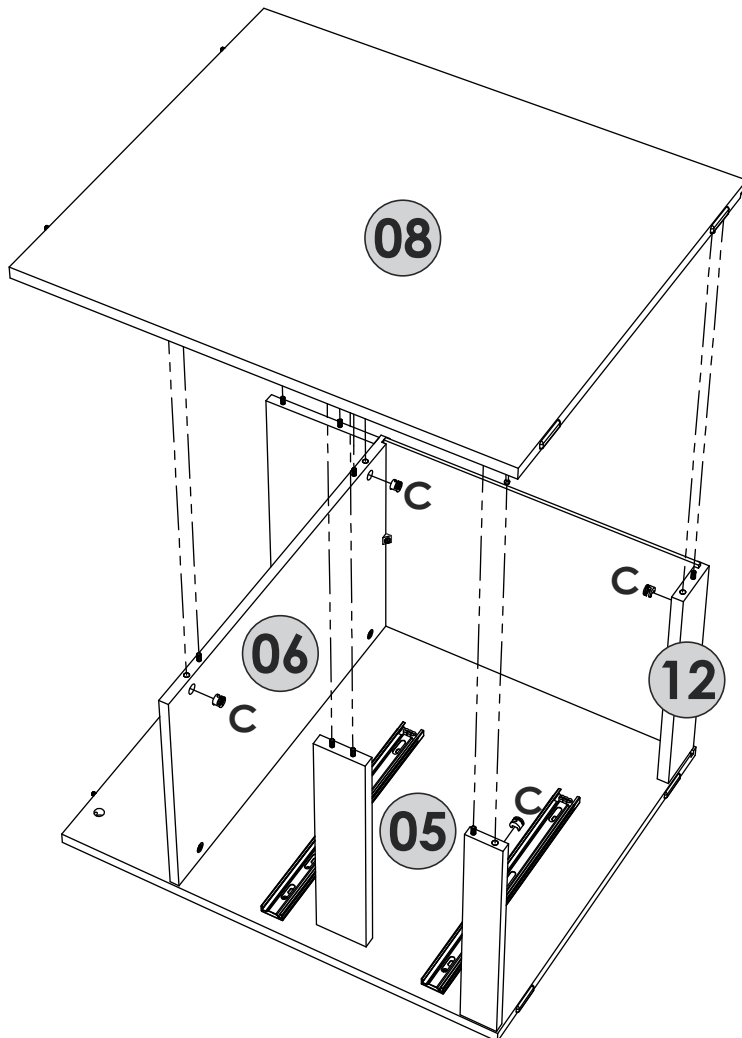

04

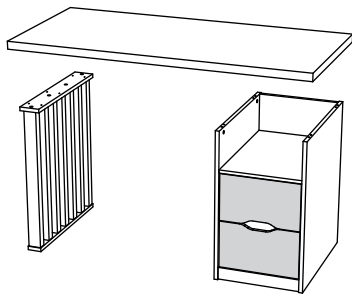

15

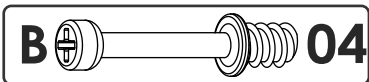
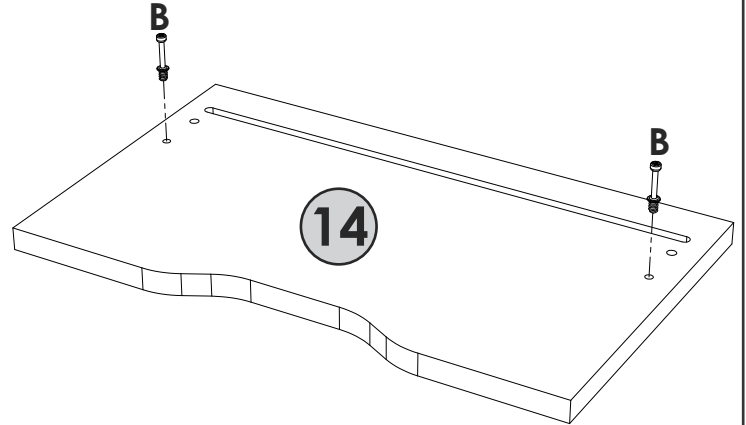
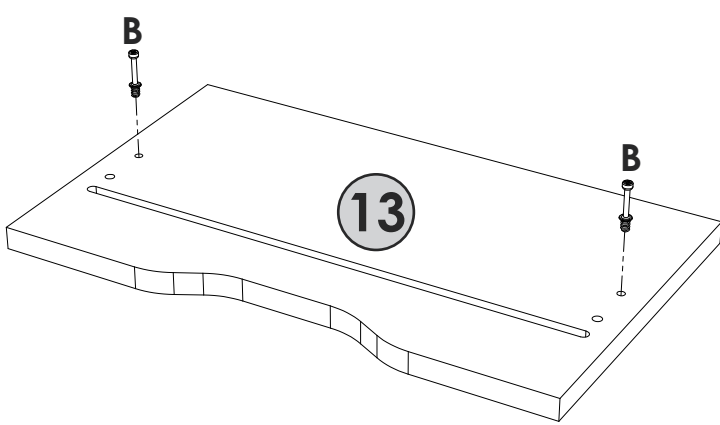

16

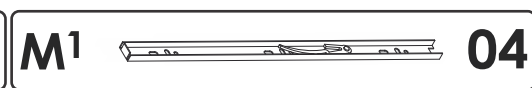
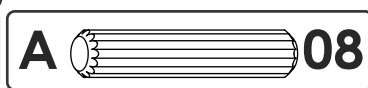
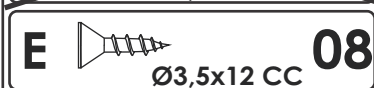
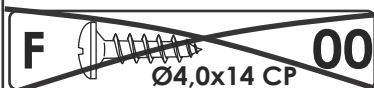
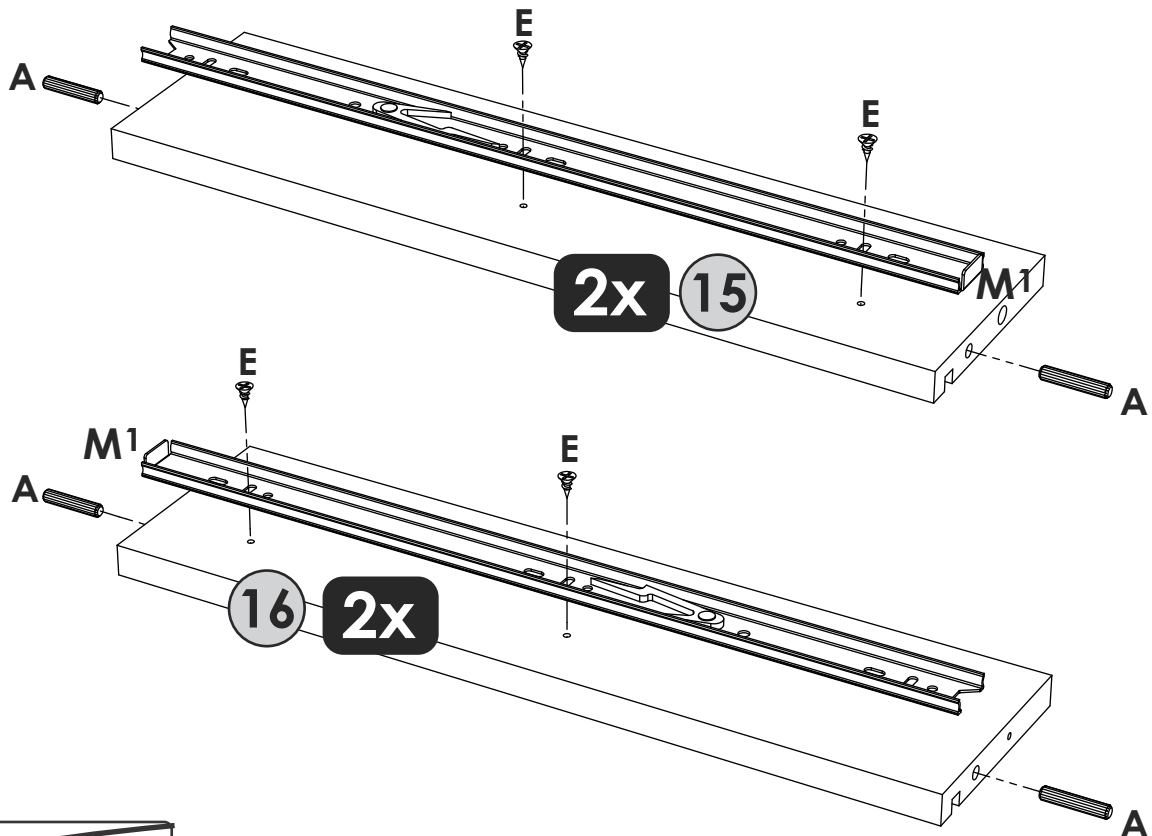
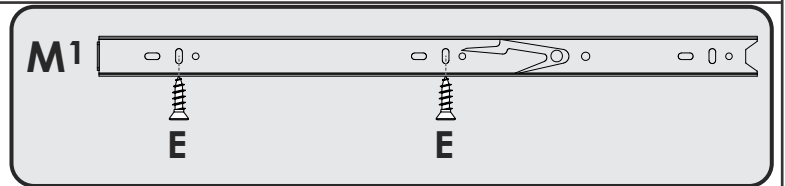

17

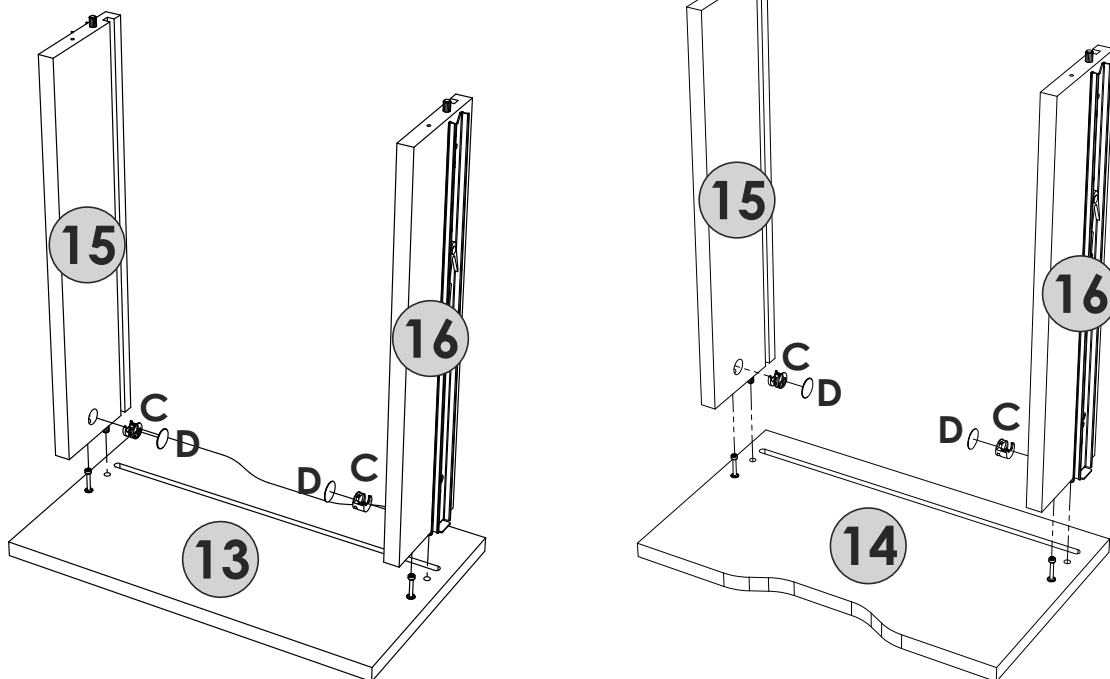

18

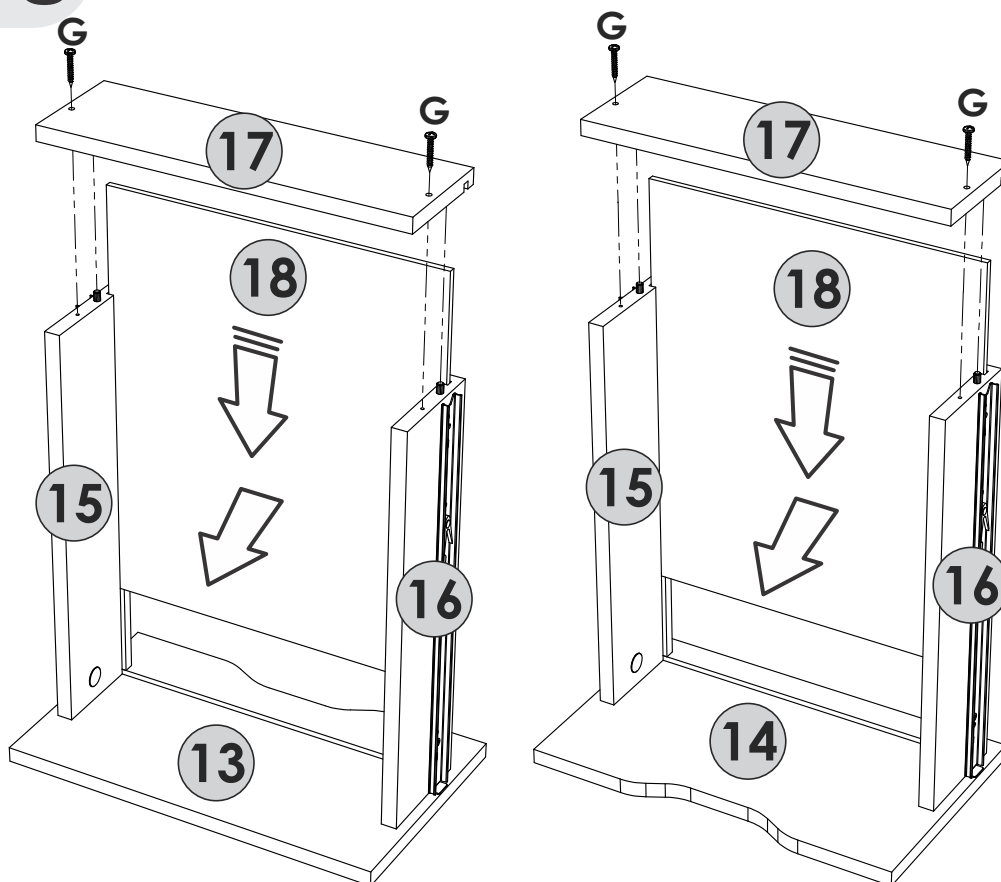

Lado do acabamento virado para dentro

Lado recubierto para dentro

Revested side turned inside



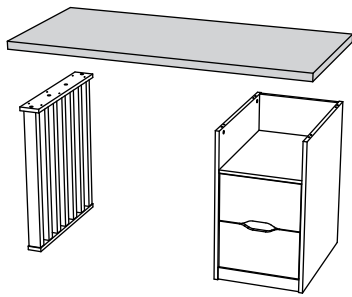

19

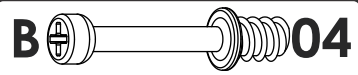
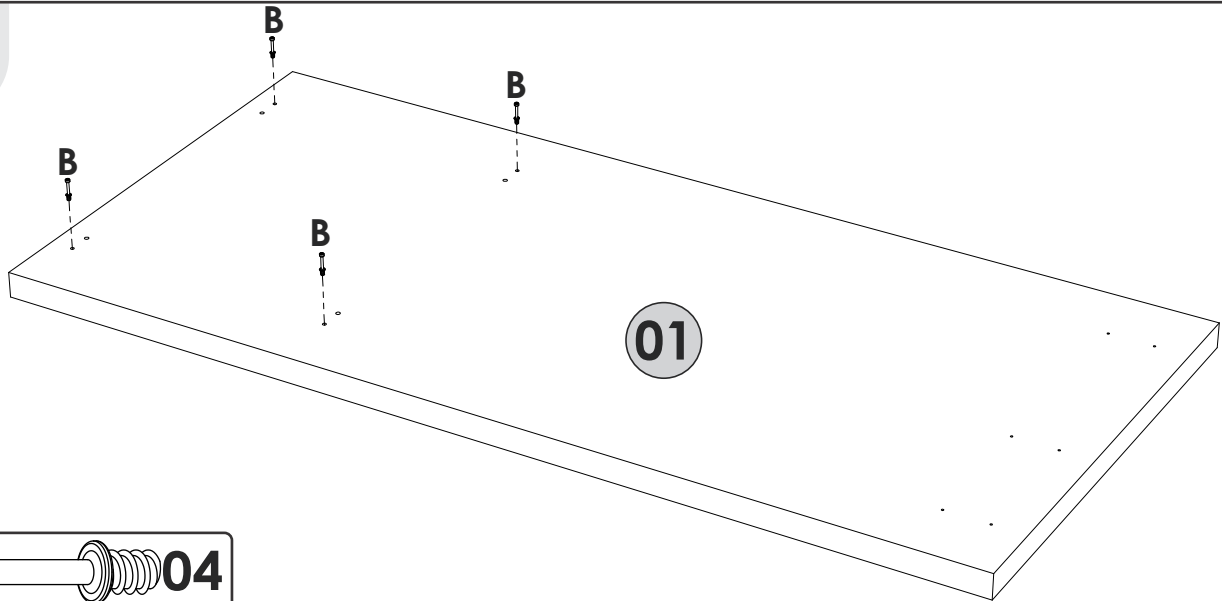

20

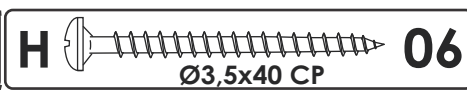
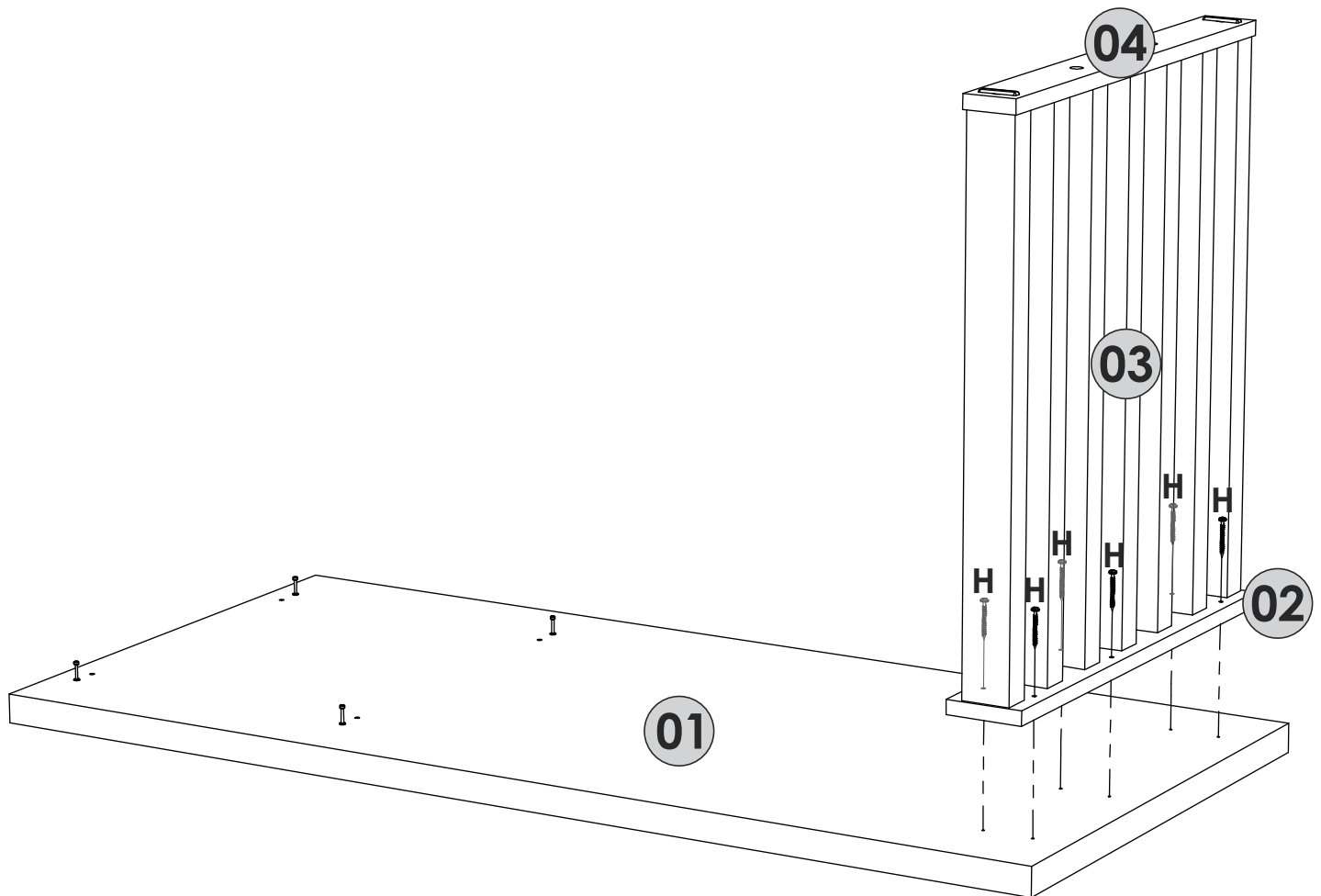

21

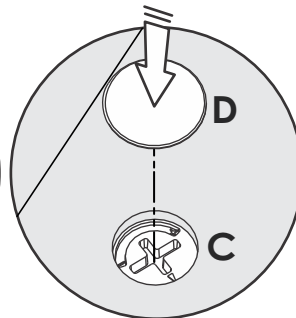
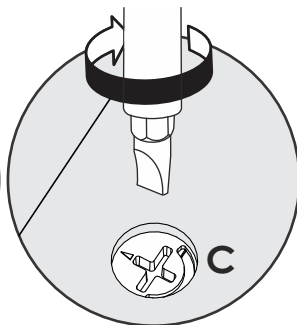
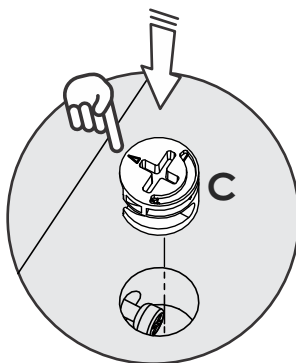
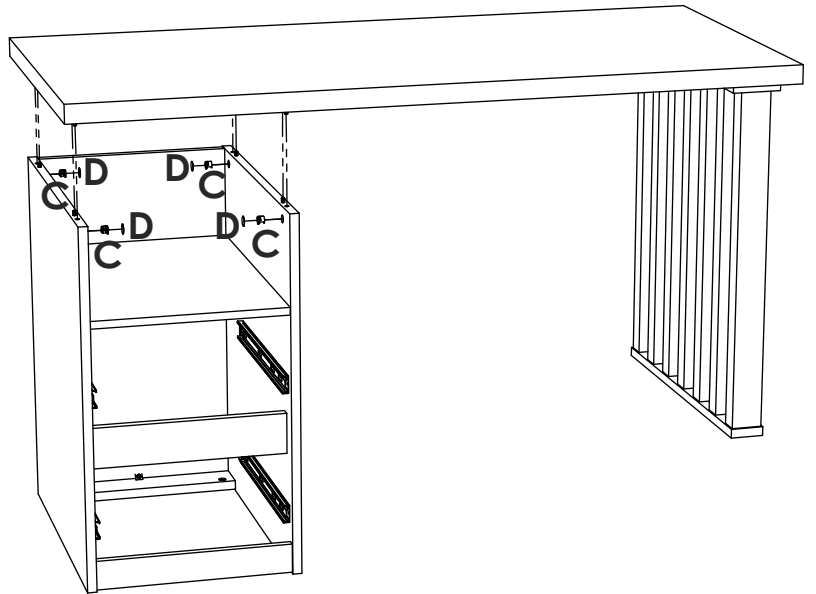
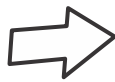
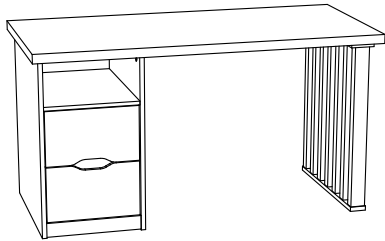
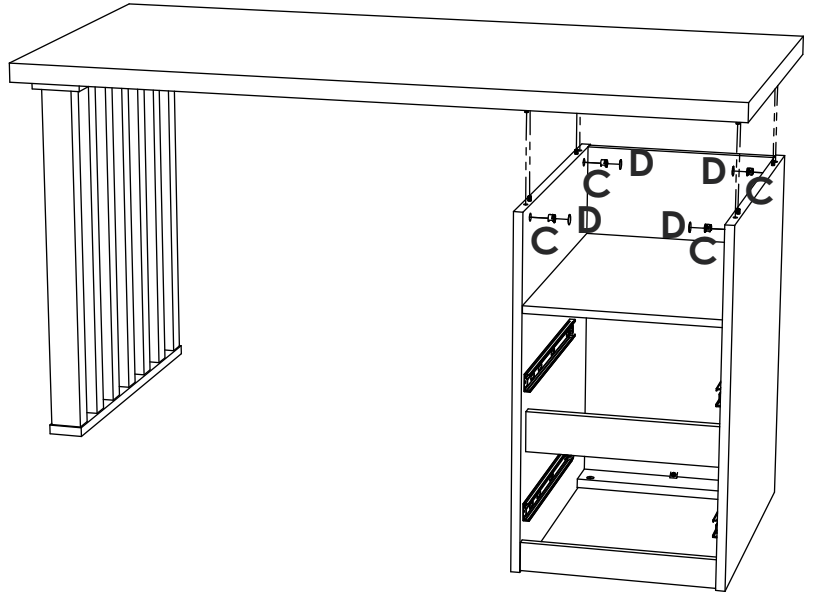
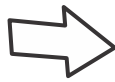
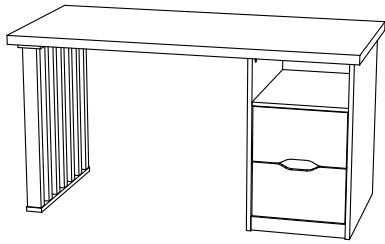
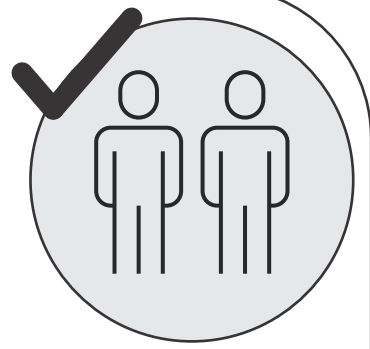
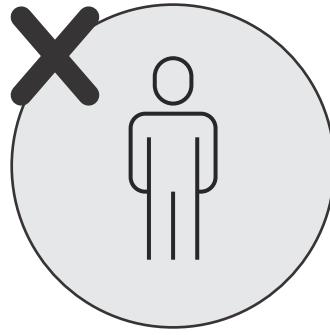
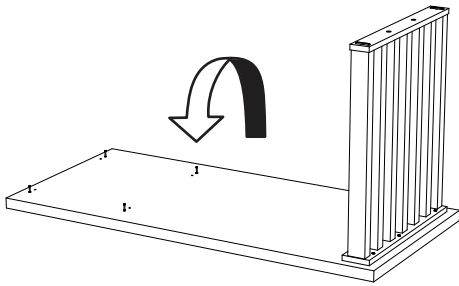

C



04

D



04

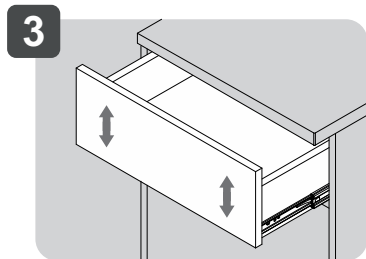
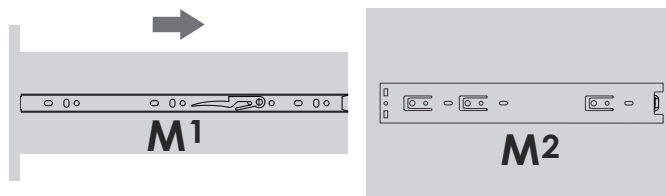
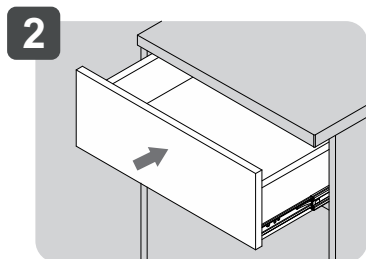
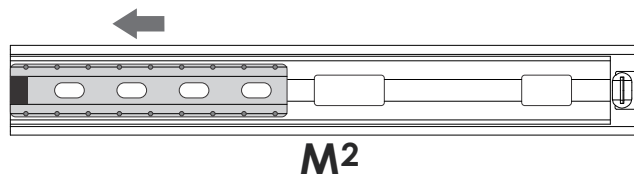
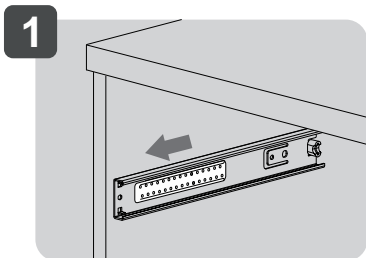
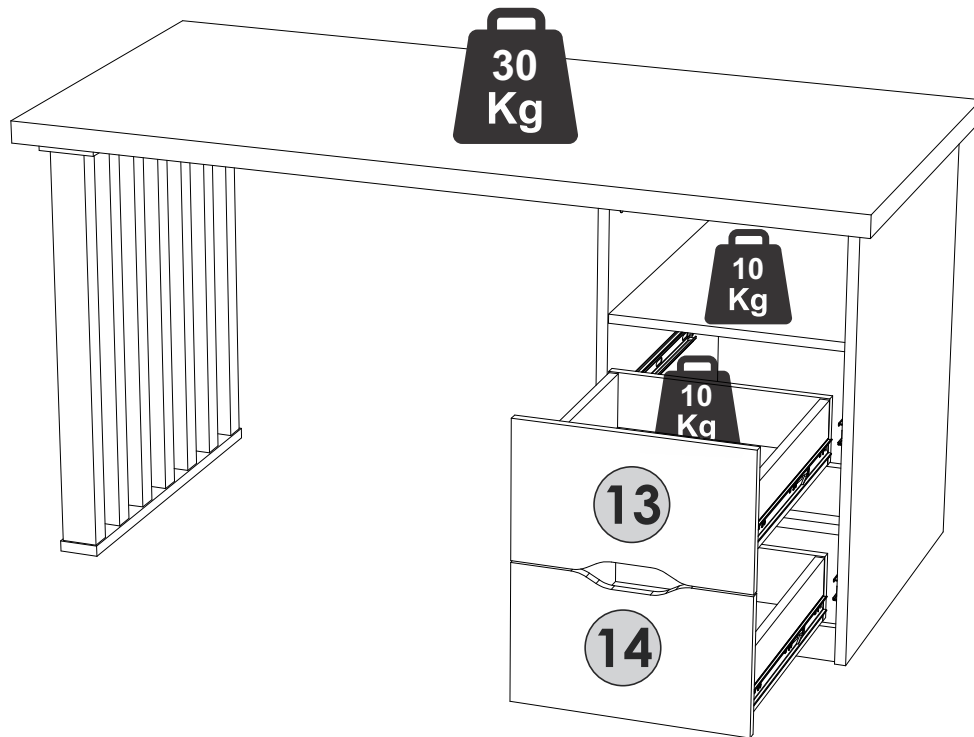

.1 **Ajustar a gaveta e colocar os parafusos**
 Ajustar el cajón y poner los tornillos
 Adjust the drawer and put the screws

M1

.2

M1 **E** **E**

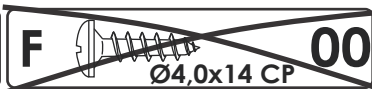
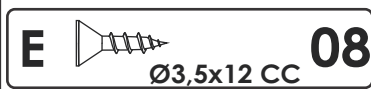

Obrigado

POR SUA CONFIANÇA EM NOSSO TRABALHO!



Esperamos que sua experiência de compra, montagem e instalação tenha sido perfeita!

Desejamos que seu móvel possa tornar seu Home Office, casa ou escritório, um ambiente muito mais agradável e organizado, fazendo seu trabalho, estudo ou descanso ser muito mais proveitoso!

APROVEITE SEU MÓVEL ARTANY!

Se tiver alguma dúvida, sugestão ou comentário, pode entrar em contato no nosso WhatsApp (41) 99242-8497, telefone (41)3556-1550, ou email artany@artany.com.br



Gostou? Compartilhe este momento e marque a gente!



@artanymoveis



ARTANY®

Arte em Home Office